



Box 1087  
Weyburn, SK, Canada  
1-866-940-4411

# EJ603517

## Extender

Fits JD- 17" diameter High Capacity  
augers on  
60, 70 and S series combines

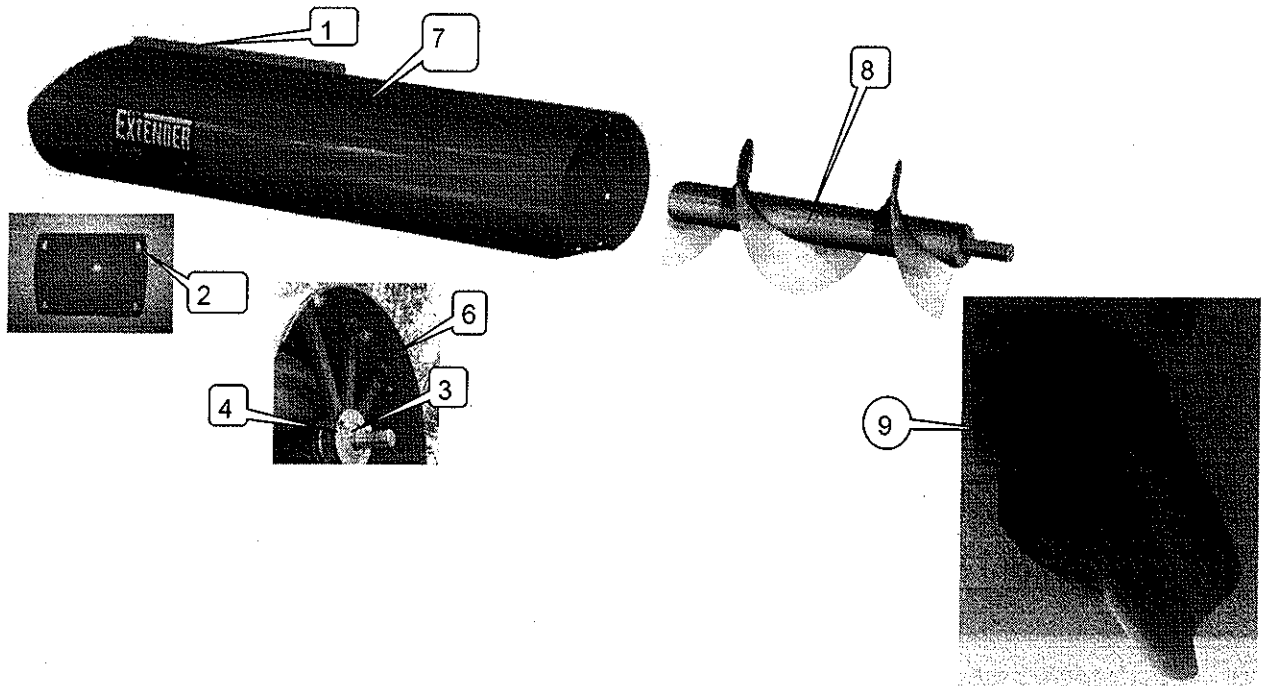

Hardware Kit consists of Items 1-5

Description	Part Number	QTY
1. Bolt Package	EBPKEJ70-14	1
2. Access Inspection door	EJ603500-DR	1
3. Bearing & Collar	AEL205-100D1	1
4. 52 mm flangettes	52mm	2
5. Clamp support bracket	EJ603517-SPSB	2
Add hardware kit to items(6-9) in 72"x 23.5x 20.5 box		
6. Hanger Bracket	EJ603517-HB	1
7. Outer Tube/clamp	EJ603517-OT	1
8. Auger Unit	EJ603517-A	1
9. Spout	EJ603517-SP	1

# EXTENDER-EJ603517

By: Stewart Steel Inc.

## COMBINE UNLOADING AUGER EXTENSION FOR:

John Deere for Models 9660 to 9870STS

### Installation Instructions:

1. Remove plastic spout and grain saver door. Remove 4 bolts that hold up bearing support at end of auger tube. Save as they must be re-inserted after Extender tube is installed.
2. Slide on The EXTENDER's outer tube against the edge of the unloading auger's tube, by sliding the sleeve portion over the present tube. Install all sleeve bolts loosely. Make sure bolts are at top of tube and that the 4 slots for the original bolts for the hanger bracket line up for the original hanger bracket. Re-install 4 bolts holding up factory hanger bracket loosely. Tighten clamp bolts on Extender tube first and then the 4 hanger bracket bolts. Install 5/16 x 3/4" bolts with locknuts from inside out on 6 holes(Figure 4) . This strengthens the band where the outer tube and sleeve are welded together.
3. Slide hex centre stub(figure 5) on to end-shaft of auger until up against original bearing & hanger bracket. DO NOT replace factory 8mm Bolt and flat washer.(Figure 5) Tighten 2 set screws on hub. Slide extender auger in place with flighting approx. 180 degrees from the original auger.  
**THIS IS TO ALLOW THE GRAIN TO PASS THROUGH THE ORIGINAL HANGER BRACKET AND THEN GET PICKED UP BY THE OUTER AUGER**  
Slide auger on far enough to fit over flange on hub(Figure 6). Install 6 - gr-8 bolts and lock washers through flange on auger to hub. Do not tighten until step 4
4. Mount new hanger bracket with 3/8" carriage bolts flat washers and locknuts. Mount bearing and flangettes at the outer end(on outside of hanger bracket) securing with locking collar to hold auger in proper place. Reach in through window and tighten 6 grade 8 x 3/8 bolts securely.(It would be advised to use locktite on these bolts as well.)
- 5.Run auger to see if allignment is proper  
Special Note: If there is vibration in the auger after running it lossen the 6 - 3/8x 1 gr. 8 bolts, turn auger over a few times and retighten. Vibration should disappear.
6. Weld Auger hub and Auger shaft hub together. Weld hub 1" every 1/4 turn
7. Replace factory grain saver door bracket up to its position in the end of the new auger tube.
8. install plastic discharge spout in desired position using new hardware supplied SEE (FIGURE 10 & 11)
9. Mount inspection door by using 5/16 wing nuts (Figure7)

Figure 4

# Rear Hex Hub

figure 4f

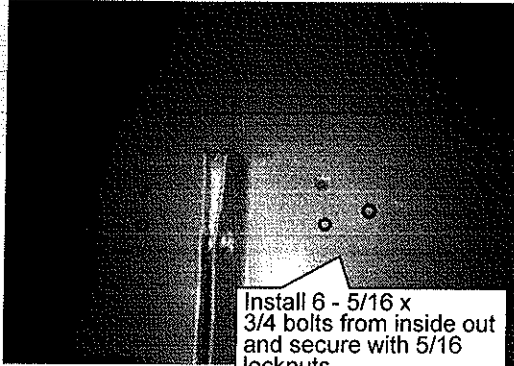

Remove 8mm bolt and Washer

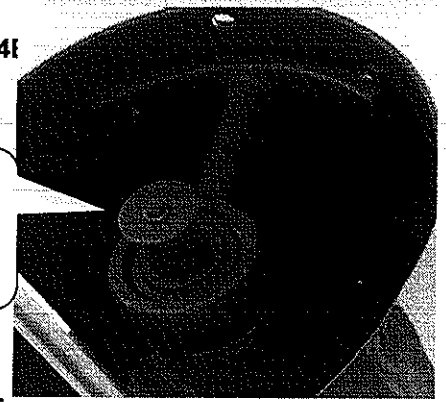
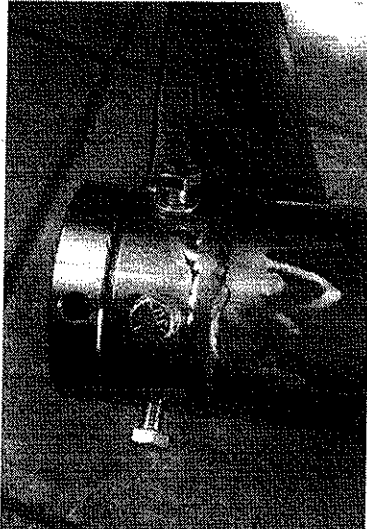

figure 5

Figure 6



Tighten set screws

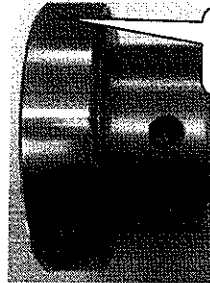

Figure 7



**WARRANTY: STEWART STEEL INC. WARRANTY COVERS ALL THE ABOVE PARTS FOR A PERIOD OF 1 YEAR FROM TIME OF PURCHASE. THE WARRANTY DOES NOT COVER ANY PARTS MADE AND SOLD BY THE ORIGINAL MANUFACTURER OR ANY PARTS THAT WERE PART OF THE ORIGINAL COMBINES CONSTRUCTION.**

**CAUTION: NEVER LEAVE UNLOADING AUGER FULL UNLESS ABSOLUTELY NECESSARY!**

## Install Instructions EJ603517 Spout

1. Mount spout by sliding bottom of spout over grain saver door and then by lifting end of spout upward until evenly over auger tube, prying the top tabs upwards in order to clear the tube.(Figure 10)
2. Line up top hole and start threading in 1/4" x 1" flanged hex bolts
3. Line up rest of holes and start threading in 1/4" x 1" flanged hex bolts and Securely tighten all nine 1/4" x 1" flanged hex bolts.

**NOTE\***

When using original JD Spout use 1/4" x 1" flanged hex bolts to secure spout to tube

figure 11

Figure 10

